

# Product Manual

## ICC1-IR

---

IR TV Controller, 1-way RF Coax Control

Ver. 5.3 July 12, 2010



17630 Davenport Road, Suite 113 • Dallas, TX 75252  
Phone: 972-931-2728 • Toll-Free: 888-972-2728 • Fax: 972-931-2765  
E-Mail: [Sales@crwww.com](mailto:Sales@crwww.com) • Website: [www.crwww.com](http://www.crwww.com)

## Table of Contents

<b>Overview</b> .....	<b>3</b>
New Features (Rev 3.0 – 5.2) .....	3
<b>Specifications</b> .....	<b>4</b>
Physical .....	4
iCC-Net .....	4
CC-HSD Scan Sensor .....	4
Includes .....	4
<b>Installation</b> .....	<b>5</b>
AC Power Test .....	5
RF Coax and iCC-Net Operation .....	5
TV Power Sensing .....	5
Setting IR Control Codes (IR Type Mode) .....	6
IR Control Codes .....	7
Setting Device Number and Parameters (Device Mode) .....	8
Zone Switch Settings .....	8
Unit Address Settings .....	9
Installation Process and Documentation .....	9
IR Control Wiring .....	9
<b>RS-232 Control Protocol</b> .....	<b>10</b>
Overview .....	10
Command String Structure .....	10
<b>RS-232 Commands</b> .....	<b>11</b>
<b>iC-Net SmartZones</b> .....	<b>13</b>
<b>System Map</b> .....	<b>14</b>
<b>Typical RF and ICC-Net Signal Flow</b> .....	<b>15</b>
<b>Safety Instructions</b> .....	<b>16</b>
<b>Limited Warranty and Disclaimer</b> .....	<b>17</b>

## Overview



The ICC1-IR IR TV Controller delivers economical 1-way control for TV power, volume, and channels, receiving iCC-Net network commands over the same broadband coax that carries the CATV channels. Compact in size and price, the ICC1-IR features sensed power on/off control and intelligent tuning from a channel list stored in onboard non-volatile memory.

- Controls most brands of IR-controlled TVs
- Manages channel access by changing the TV's internal available channel list
- Delivers absolute power control with included CC-HSD scan frequency sensor
- Networks up to 4,000 TVs through the ICE-HE Ethernet Head-End
- Receives 1-way individual and zone commands from a single RS-232 port on the HE
- Operates over same RF coax cable as CATV channels
- Exclusive SmartZone architecture controls hundreds of controllers with a single command
- Low-loss internal RF tap saves amplification and installation costs
- Provides LED feedback for network, IR control, and power status
- Restores all power and channel status after loss of power from data stored in non-volatile memory
- Mounts on the back of the TV for simplified control and RF installation
- Operates with Contemporary Research ABC Media System and iCE Director software, as well as from RS-232 protocol from a custom-programmed PC or control system
- Senses TV power from included sensor or logic level input
- Includes CC-HSD Scan Sensor, CC-IRE IR Emitter, RF loop cable, mounting Velcro, and 12VDC power supply (U.S. only)
- Firmware updateable via modem or PC software (available soon)

### New Features (Rev 3.0 – 5.3)

- Units shipped with new processor start with serial number 221-5011-001, Rev 3.0 or higher  
Serial number can be read as follows—xxx (production run) - 5011 (ICC-IR)
- Added Finlux IR commands (3.0)
- Added Zenith\_2 and Philips\_2 commands, allowing discrete Power On and Off commands to many Zenith and LG models of LCD and Plasma displays (3.1)
- JVC and Sampo (Gateway, NetTV, ViewSonic) discrete IR codes (3.2)
- Samsung and Gateway LCD discrete IR codes (3.3)
- ViewSonic LCD (3.4, 3.8)
- JVC\_3 (1-digit tuning) and LG/Zenith\_3 (3.5)
- Sharp and Daewoo IR commands (3.7)
- Channel Entry command T3 (3.7)
- New LG, H&B, Sony, and Dell commands (4.0-4.1)
- Adds HD dash-style tuning for Sony and Sharp (4.5-4.6)
- 8 second delay after power on for Akai
- Viewsonic LCD (4.8)
- New! The S2 set of switches can be used to test IR control of display On and OFF (Page 5)
- Visio with discrete on and off (5.3)

## Specifications

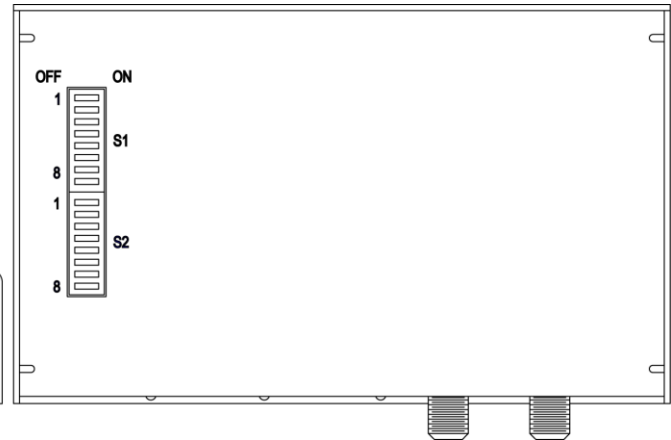
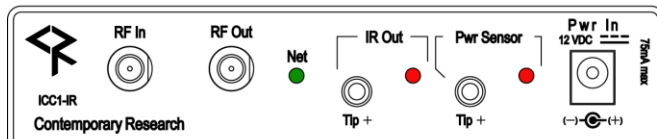

### Physical

Size:	5.5" [140mm] wide x 1.1" [28mm] height x 3.4" [86mm] deep
Weight:	8 oz [226g]
Enclosure:	All aluminum with durable black powder coat paint
Mounting:	Mounts rear of TV

### Rear Panel

RF In	'F', female, 75 ohm impedance, RF from CATV system, iCC-Net control
RF Out:	'F', female, 75 ohm impedance, RF to TV, less than -1.5 dbmV loss
Net LED:	Green LED for iC-Net bus and DC power, flashes once per second if active
IR Out:	3.5mm jack for CC-IRE IR Emitter cable or compatible CC-IRS serial cable Supports carrier frequencies up to 62 KHz Shipped with CC-IRE cable, 10 foot with stick-on IR emitter
IR Out LED:	Red LED lights when sending IR commands
Power Sensor:	3.5mm jack for included CC-HSD scan sensor Also acts as logic level input, switch to GND to signal power on
Power Sensor LED:	Red LED lights when sensor indicates power on
Power In:	2.1mm coaxial jack (inside center conductor positive), 75 Ma maximum 11.5 to 16.5 VDC, 12 VDC typical (may be unregulated) North American version includes UL/CSA listed wall power supply
DIP Switches:	S1 and S2, located on bottom of unit, sets IR code operation and device number

### iCC-Net

Operation:	1-way control, carried over the same RF coax connection as TV channels
Data Receive:	Mid-band VHF, 74.7MHz, sent from ICC-HE -25 to +35 dBmV signal level

### CC-HSD Scan Sensor

Range:	Senses presence of TV scanning, from 15-35 KHz, magnetic pick-up
Includes:	3.5mm plug, 4ft. cable, stick-on TV sensor

### Includes

- CC-HSD Scan Sensor
- CC-IRE IR Emitter
- RF Loop cable, 18"
- 12 VDC power supply, 100 mA, (domestic US shipments only)
- Mounting Velcro for unit and CC-HSD

## Installation

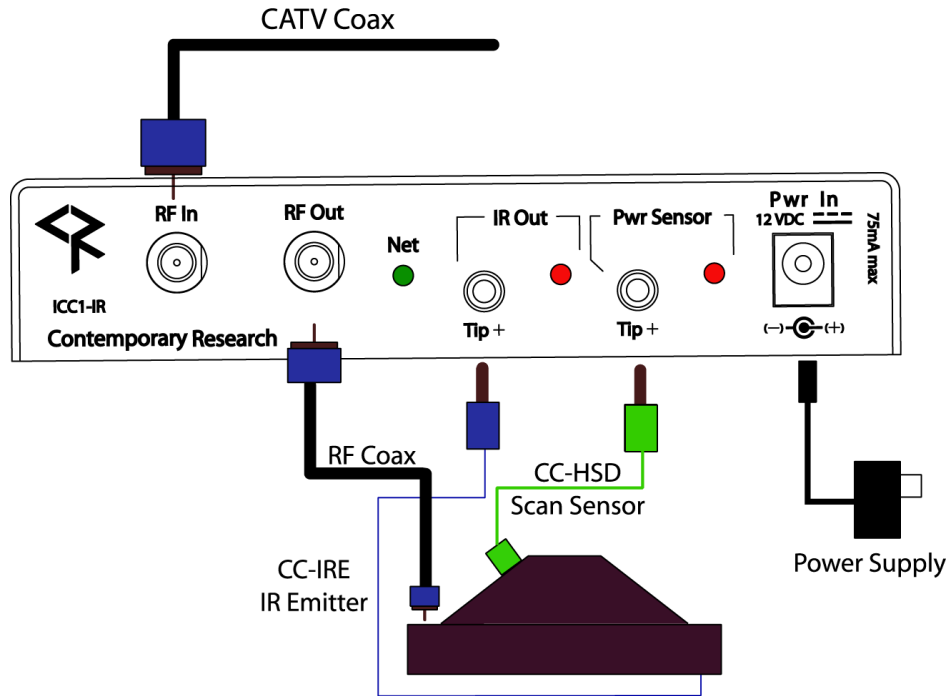

### AC Power Test

1. Insert DC power supply plug into 12 VDC jack.
2. Plug power adaptor into AC wall outlet.
3. The Net LED should turn on and stay lit.

### RF Coax and iCC-Net Operation

1. Connect the TV to CATV and observe quality of RF broadcasting. A low-quality CATV system can also affect performance of the iCC-Net commands. If needed, fix CATV problems before installing the system.
2. Connect the CATV RF Coax cable into the RF In input on the iCC1-IR.
3. If the iCC-Net signal is operating, the Net LED will blink once per second.
4. Connect the RF loop cable from the RF Out jack to the TV's RF connector (remember, you lose less than 1.5 dbmV by going through the ICC1-IR'S internal RF tap).

### TV Power Sensing

1. Insert the CC-HSD Scan Sensor plug into the Power Sensor jack.
2. Turn on the TV using the TV's power button.
3. Move the CC-HSD sensor block around the rear of the TV to pick up scanning signal from the TV's horizontal transformer.
4. Watch the Power Sensor LED as you move the sensor, stop moving when the LED lights steady.
5. Turn the TV on and off from its own power button, testing if the unit is reliably sensing power.
6. Mount the sensor to the TV, using the enclosed Velcro tape.

**Tip:** *The best location for the sensor is usually on the lower left rear corner side corner (looking from the front), and it may help to rotate the sensor to search for best performance.*

**Tip:** *IR control test: When you install the IR cable, flip S2 Switch 6 ON. Then flip S2 Switch 1 ON to send an IR power command. Turn Switch 1 OFF, then turn Switch 2 on to send and Off IR command. After testing, turn S2 Switch 6 OFF.*

## Installation

### Setting IR Control Codes (IR Type Mode)

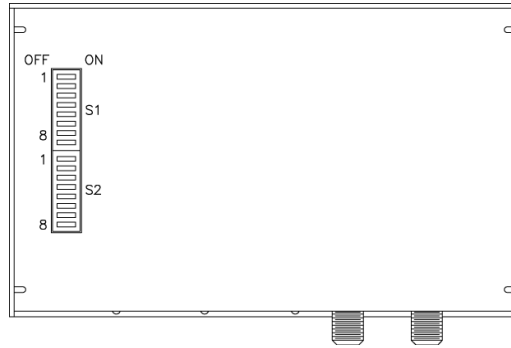

The DIP switches S1 and S1 at the bottom of the ICC1-IR serve in two modes, IR Type, Channel Entry and Device Number, determined by S2 Switch 6 and S2 Switch 5. In this section, you'll set up the manufacturer's IR codes sent from the IR Out port. These may have been set at the factory, or you'll need to set them yourself.

1. Apply DC power to the ICC1-IR.
2. If the unit's device number has already been set, note the current settings for S1 switches 1-8 and S2 switches 1-4.
3. Set S2 Switch 6 to ON.
4. Look at the IR Control Code chart on next page and select the desired value.
5. Set S1 Switches 1 – 6 to match the value. For example to select the Sony codes, turn on S1 switches 1 and 3, adding up to 5 to match the value in the Manufacturer IR chart below.
6. Set S1 Switch 7 to On if you want the unit to ignore the power sensor input
7. Set S1 Switch 8 to OFF for toggling Power On/Off command typical for most TVs. (There are a few international TVs that use Key 1 for Power On)
8. Set S1 Switch 8 and S2 Switch 6 to OFF. (See Channel Entry option below)
9. If unit's device number had been set before, return S1 switches 1-8 and S2 switches 1-4 to previous positions.

S1	Off Value	On Value
1	0	1
2	0	2
3	0	4
4	0	8
5	0	16
6	0	32
7	0 - Use Power Sensor	64 - Ignore Pwr Sensor
8	0 - Toggle power	128 - Key 1 = Power On
S2		
1		
2		
3		
4		
5	Channel Entry Off	Modify Channel Entry
6	<b>Device Number Mode</b>	<b>IR Type Mode</b>
7		
8		

**Modify Channel Entry: Turning on S2 Switch 5 and 6 allows modification of the Channel Entry mode.**

1. Leaving Switch 6 on, Turn on S2 Switch 5.
2. Set Switches 1-8 to set alternate method of channel enter (see T3 command, page 10).
3. Turn S2 Switch 6 off first (important!), and then reset Switch 5 and other switches.

## Installation

### IR Control Codes

Code	MFG	Display	Power	Notes	Ver
1	Zenith	TV	Sensor	Use CC-HSD	1.2
2	Panasonic	TV	Sensor	Use CC-HSD	1.0
3	Toshiba	TV	Sensor	Use CC-HSD	1.5
4	Hitachi	TV	Sensor	Use CC-HSD	1.5
5	Sony/Westinghouse LCD	TV	Sensor	Use CC-HSD	1.5
6	Grundig	TV	Sensor	Use CC-HSD	1.6
7	Magnavox/Philips	TV	Sensor	Use CC-HSD	1.7
8	RCA	TV	Sensor	Use CC-HSD	1.7
9	Sony 2	TV	Sensor	Use CC-HSD	1.8
10	Panasonic 2	TV	Sensor	Use CC-HSD	1.9
11	Mitsubishi	TV	Sensor	Use CC-HSD	1.9
12	Finlux	TV	Sensor	Not in V 2.2-2.3	3.0
14	Panasonic 3	TV	Sensor	Use CC-HSD	2.0
15	Sharp	TV	Sensor	Use CC-HSD	2.0
19	JVC	TV	Sensor	Use CC-HSD	2.1
20	ViewSonic Tuner	Tuner	N/A		2.2
21	LG/Zenith_2	PDP/LCD	Discrete		3.1
22	Philips_2	PDP/LCD TV	Discrete		3.1
23	JVC_2	PDP/LCD TV	Discrete		3.2
24	Sampo Discrete NetTV Gateway ViewSonic	PDP/LCD TV	Discrete		3.2
25	Samsung	PDP/HD	Discrete	14-second delay	4.4
26	Gateway	LCD	PC Sensor		3.3
27	Viewsonic LCD	LCD	PC Sensor		3.4
28	JVC_3	TV	Discrete	1-Digit tuning, 1-9	3.5
29	LG/Zenith/Dell_3	PDP/LCD	PC Sensor		3.5
30	Sharp_2	PDP/LCD	Discrete		3.7
31	Daewoo	TV	PC Sensor		3.7
32	Viewsonic LCD 2	LCD			3.8
33	H&B	PDP/LCD	Discrete	B Series	4.0
34	H&B	PDP/LCD	Discrete	V Series	4.0
35	Sony	PDP/LCD	Discrete		4.0
36	Dell W4201C (RC6)	LCD	PC Sensor		4.1
38	Olevia	LCD	PC Sensor	26-sec power on delay	4.2
39	Akai	LCD	PC Sensor	8-second delay	4.7
40	Sanyo	TV	Sensor	Use CC-HSD	4.3
41	ILO/Insignia/Dynex/Zenith	TV	Sensor	Use CC-HSD	4.3
42	Viewsonic LCD	LCD	Discrete*		5.0
43	Sony	LCD	Discrete	FWD-50PX2	5.2
44	Vizio	LCD	Discrete		5.3

**PC Sensor Setup:** LCD marked **PC Sensor** (Power Current Sensor) do not have discrete IR power commands. Instead, the ICC1-IR will wait for an "OFF" signal from a power sensor before it sends an ON IR command. We recommend the Power Current Sensor sold by Display Devices, [www.displaydevices.com](http://www.displaydevices.com) for sensed absolute power control.

If you want to set the control for unsensed toggling power, turn DIP S1, Switch 7 ON when you set the IR code with the DIP switches. If you are using IC-Send or SignStream Media/Display Express Special Command feature, send the command T1, with the IR code value + 64. For example, to set Olevia controllers to toggling power, send the command T1, 102 (38+64).

## Installation

### Setting Device Number and Parameters (Device Mode)

In the next step, you'll need to set up the device number and operation parameters for the ICC1-IR. Notice that the functions of the S1 and S2 switches change when you set the unit in Device mode.

1. Make sure S2 Switch 6 is OFF (unit in Device mode).
2. Set the **Device number** by turning on the switches that add up to the desired device number. For example, for Device #513 (1<sup>st</sup> device in Zone 2), S1 Switch 1 (1) and S2 Switch 2 (512) ON.
3. **IR Carrier:** Set S2 Switch 5 to OFF to send carrier with IR commands (default), ON to turn off carrier.
4. **Power Sense Level:** Set S2 Switch 7 to ON for high sensitivity for power (default), set to OFF if you need to lower sensitivity (usually 2 adjacent TVs – side-by-side or through a wall).
5. **IR Out Level:** Set S2 Switch 7 to ON for high signal level (default), set to OFF if you need to lower IR signal level to TV.

S1	Off Value	On Value
1	0	1
2	0	2
3	0	4
4	0	8
5	0	16
6	0	32
7	0	64
8	0	128
S2		
1	0	256
2	0	512
3	0	1024
4	0	2048
5	IR Carrier On	No Carrier
6	<b>Device Mode</b>	IR Program Mode
7	Power sense low	Power sense high
8	IR Out low	IR Out high

Device Number Setting

\*Values in gray cells are the default settings.

### Zone Switch Settings

To define the controller's Zone, use the following pattern of switches ON for the S2 DIP.

Zone	Value	1	2	3	4
		256	512	1024	2048
1	256	X			
2	512		X		
3	768	X	X		
4	1024			X	
5	1280	X		X	
6	1536		X	X	
7	1792	X	X	X	
8	2048				X
9	2304	X			X
10	2560		X		X
11	2816	X	X		X
12	3072			X	X
13	3328	X		X	X
14	3584		X	X	X
15	3840	X	X	X	X

## **Unit Address Settings**

The unique address of the controller is the combination of the values of the Zone (S2) and Unit (S1) switches. For example, the first controller in Zone 1 would be set to Zone 1 (256) in S2 and 1 (1) on S1, or 257. To control all the displays in Zone one, Display Express sends a command to device 256. To control just the first unit, create a Preset addressed to 257.

## **Installation Process and Documentation**

Most dealers will pre-configure the controller's address before hanging displays. After setting the address, use a label that states the unit's address and location. Some use this method:

### **Room 305 - 515 - 12/2**

The first identifies the location/name of the display. The second shows the specific address. The last set shows the switches in S1/S2 that are set to ON.

It's a good idea to define all this first in a spreadsheet, with the columns defining the name, address, S1 and S2 ON settings. Then, one person can set up all the controllers and label them.

Once the controller is configured and labeled, it's easier for less-trained installers to Velcro the controller on the back of the display, provide power, and hang the displays.

It's much easier to pre-configure ahead of time than perform the task once the displays are installed.

## **IR Control Wiring**

1. Connect the CC-IRE IR Emitter plug into the IR Out jack.
2. Mount the emitter cube to the TV case where the TV receives IR commands.
3. Mount the ICC1-IR to the TV using included Velcro tape.
4. Connect DC power to unit.

## RS-232 Control Protocol

### Overview

RS-232 control for up to 4000 TV Controllers is provided through an iC-series Head-End Network Controller. The ICC-HE Head-End manages iC-Net communication over RF Coax to ICC1 (1-way) and ICC2 (2-Way) TV Controllers as well as ICW TV Controllers over twisted-pair Cat3/5 wiring. The ICW-HE Head-End operates on the twisted-pair network only.

Each TV Controller is assigned a unique device number from 1 to 4000 to which control commands are addressed. The devices are organized into 16 zones of 255 devices. All the devices in each zone will respond to a single "virtual device number" — one device number that represents all devices in each zone. There is also a global device number, 4095, that will command all devices in the system. This feature dramatically speeds up system operation and programming, because one command can affect an entire group of devices—or all. To take advantages of this feature, review the section **iC-Net Zones** in this manual.

In ABC-Net Media Network, we reserve the first group of devices, 1-255, for components operating on a connected control system. Zones 1-16 are used for CR TV Controllers, Video Display Controllers and Tuners. As it's unlikely any system will use all 4000 devices, this may be a good device standard for your system as well.

The Remote RS-232 port on the Head-End Network Controller can communicate from 1200 to 38.4K baud. The factory default setting is 19.2K baud, 8 data bits, No parity, and 1 stop bit.

### Command String Structure

Characters in command strings are expressed in a combination of hex and ASCII characters. For clarity, the following protocol examples use the following conventions:

- Single-byte hex numbers are preceded by the '\$' symbol
- ASCII characters or strings are enclosed in single quotes
- Numbers not marked as hex or ASCII are a single decimal byte
- Parameters shown in < > brackets are single byte
- A series of multiple commands or parameters are set apart by [ ] brackets
- Commas separate the bytes, but are not part of the protocol
- Double quotes enclose the command string, but are not part of the protocol

### Command format:

"\$A5,<dh>,<dl>,<ncb>,<cmd1>,<parameter> [<cmdN>]"

<b>\$A5</b>	Starts the command
<b>&lt;dh&gt;</b>	The zone or high order byte of the device
<b>&lt;dl&gt;</b>	The unit or low order byte of the device (0 for global zone)
<b>&lt;ncb&gt;</b>	The number of command bytes to follow
<b>&lt;cmd1&gt;</b>	The first command byte
<b>&lt;parameter&gt;</b>	Command parameters (not used by all commands)
<b>[&lt;cmdN&gt;]</b>	Multiple commands can be concatenated, with byte count added to <ncb>

## RS-232 Commands

Command	Description
<b>Power</b>	This series of commands uses the sensed power capability of the ICC1-IR.
<b>Power Off</b>	<b>P0</b> "\$A5,<dh>,<dl>,2,'P0' " (6 bytes)
<b>Power On</b>	<b>P1</b> "\$A5,<dh>,<dl>,2,'P1' " (6 bytes)
<b>Power Toggle</b>	<b>PT</b> "\$A5,<dh>,<dl>,2,'PT' " (6 bytes)
<b>Volume</b>	<b>VL</b> "\$A5,<dh>,<dl>,3,'VL',<vol level>" (7 bytes)  Sets TV volume level 0 = Mute 1 – 63 = Minimum level (1) to maximum volume (63)
<b>IR Type</b>	<b>T1</b> "\$A5,<dh>,<dl>,3,'T1',<type> " (7 bytes) – Sets IR device type Identical to using DIP switch to set IR control codes. Specify value to match IR code type.  Add 64 to the IR code to set the ICC1-IR to ignore the power sensor – if the type is specified as Sensor – discrete types always ignore the sensor input.
<b>Channel Entry</b>	<b>T3</b> "\$A5,<dh>,<dl>,3,'T3', <format>" (7 bytes) – Modifies entry format for channels Zero (0) value uses format defined by IR Type.  Add the total value for the formats below:  128 = Add Enter after channel number (105 + Enter) 64 = Add +100 to channel number (105 = +100, 05 – use 3 digit tuning) 3 = 3 digits (Ex: 007, 032, 105 – ICC1-IR inserts leading zeros, if needed) 2 = 2 digits (Ex: 07, 32 – ICC1-IR inserts leading zero, if needed) 1 = 1 digit (Ex: 7)  <b>Ex:</b> "\$A5,<dh>,<dl>,3,'T3', 131" Adds Enter, uses 3 digits for channel entry  <b>Tips on using Channel Entry:</b> The IR Type setting includes a channel entry format normally used by the displays in that control group. However, sometimes a manufacturer changes the entry format for some models. Using the Channel Entry command, you can adapt to a different entry format without changing your system programming. For example, in the +100 Channel Entry mode, the ICC1-IR will receive a command for Channel 122 and translate that to a +100 command, followed by 22.  Note that the IR Type command sets a pre-defined Channel Entry format. If you change or re-send an IR Type command to the ICC1-IR (or change with DIP switches), you'll need to send a Channel Entry again to add the modifications.

## RS-232 Commands

<i>Ts &amp; Qs</i>		<i>The ICC1-IR responds to Q-series tuning commands as well</i>
<b>Channel Up</b>	<b>TU</b>	"\$A5,<dh>,<dl>,2,'TU' " (6 bytes) – Tunes to next channel up in Tune Ring
<b>Channel Dwn</b>	<b>TD</b>	"\$A5,<dh>,<dl>,2,'TD' " (6 bytes) – Tunes to next channel down in Tune Ring
<b>T Channel Prev</b>	<b>TP</b>	"\$A5,<dh>,<dl>,2,'TP' " (6 bytes) – Tunes to previous channel in Tune Ring
<b>Force Channel</b>	<b>TC</b>	<p>"\$A5,&lt;dh&gt;,&lt;dl&gt;,3,'TC', &lt;channel&gt;" (7 bytes) – Tunes to a specific channel</p> <p>124 = RGB 2 input on TV            125 = RGB input on TV            126 = Select TV's composite A/V input            127 = Select S-Video Input            0 = Blank video output to TV            255 = Unblank TV video (restore to previous channel)</p> <p><b>Tip:</b> Not all TVs have S-Video and RGB inputs.</p>
<b>Select Channel</b>	<b>TT</b>	"\$A5,<dh>,<dl>,2,'QT',<channel>" (7 bytes) – Tunes channel if included in TR
<b>Tune Ring</b>	<b>TR</b>	<p>"\$A5,&lt;dh&gt;,&lt;dl&gt;,&lt;ncb&gt;,'TR', [&lt;chan 1&gt;, &lt;chan N&gt;]" (variable bytes)</p> <p>This command stores a Tune Ring, <b>Analog channels only</b>, a series of preset channels accessed by channel up/down commands.</p> <p><b>Ex1:</b> "\$A5,&lt;dh&gt;,&lt;dl&gt;,6,'TR', 5,4,8,11" sets ring to channels 5, 4, 8 and 11</p> <p><b>Tip:</b> The ring follows the stored order, channels do not have to be in ascending order</p> <p><b>Ex2:</b> "\$A5,&lt;dh&gt;,&lt;dl&gt;,8,'TR', \$82,5,\$87,11" sets channels 2-5 and 7-11. You can specify a range using MSB bit for the first channel; the next byte is the last.</p>
<b>Control Lock</b>	<b>LM</b>	<p>"\$A5,&lt;dh&gt;,&lt;dl&gt;,3,'LM',&lt;control&gt;" (7 bytes)</p> <p>Locks power operation – only functional with display with power current sensor. When the control is locked, the display is locked to the power state of the ICC1-IR. For example, if the ICC1-IR power state is off, the display can't be turned on from the IR remote or TV front panel. The controller will sense the change from the power sensor and turn the set off.</p> <p>0 = Unlock, 128 = Lock</p>
<b>Tuning Style</b>	<b>H1=</b>	<p>"\$A5,&lt;dh&gt;,&lt;dl&gt;,3,'H1',&lt;style&gt;" (7 bytes)</p> <p>1 = 5-digit CableCard style tuning (1-9999)            2 = Virtual HD Major-Minor tuning (tunes to virtual channel ID in display)            3 = Physical HD Major-Minor tuning (physical channel, minor digital)</p>
<b>TC Response</b>	<b>H2=</b>	<p>"\$A5,&lt;dh&gt;,&lt;dl&gt;,3,'H2',&lt;response&gt;" (7 bytes)</p> <p>This pre-sets how the ICC1-IR will respond to TC tuning commands.</p> <p>0= Ignore, use current settings            1= Analog Only (XX-0)            2= Digital (XX-1)</p>
<b>Tune HD</b>	<b>TH</b>	<p>"\$A5,&lt;dh&gt;,&lt;dl&gt;,5,'TH',&lt;H1&gt;,&lt;Major&gt;,&lt;Minor&gt;" (9 bytes) – Digital Tuning</p> <p>Normally, the H1 parameter is 0, allowing the ICC1-IR to use the current H1 tuning format, but it could be used to force a different tuning option. When the display is set to the H1=1 mode, the Major-Minor bytes will represent the high and low bytes of the 5-digit number. In H1=2 or 3 modes, the bytes represent the Major and Minor channel numbers. Values may be in hex or decimal.</p> <p><b>Ex:</b> "\$A5,1,4,5,'TH',1,2,3" Device 260, channel 515            "\$A5,1,4,5,'TH',2,2,3" Device 260, virtual channel 2-3            "\$A5,1,4,5,'TH',3,2,3" Device 260, physical channel 2, minor 3</p>

## iC-Net SmartZones

To simplify controlling groups of devices, iC-Net is divided into 15 Zones of 255 devices. All the devices within each zone can be controlled simultaneously by sending a command to a single virtual device number.

For example, noting the zone chart below, if we send a Power On command to device #256, any TV controller numbered between 257 and 511 will instantly turn on. If we send a Power Off command to device #4095, all devices in the system will turn off.

The ICC1-IR and ICC1-232 controllers typical for many SignStream display control systems are designed to follow a Zone address format. You can use the 4 top switches in the second DIP switch (S2) to define the controller's Zone. You could stop at that point, or use the upper switches (S1) to define the controller's address within the Zone. For example, setting S2/1 On and S1/2 On defines that the controller is part of Zone 1 (256), and is the second unit in the Zone (2). The unique address of the controller would be 258 (256 + 2)

Zone	Device #	Unit	Total Device #
1	256	1-255	257-511
2	512	1-255	512-767
3	768	1-255	769-1023
4	1024	1-255	1025-1279
5	1280	1-255	1281-1535
6	1536	1-255	1537-1791
7	1792	1-255	1793-2047
8	2048	1-255	2049-2303
9	2304	1-255	2305-2559
10	2560	1-255	2561-2815
11	2816	1-255	2817-3071
12	3072	1-255	3073-3327
13	3328	1-255	3329-3583
14	3584	1-255	3585-3839
15	3840	1-255	3841-4095
All Zones	4095		

**Tip:** While many applications can use just the Zone number, it's a good practice to assign a unique Unit number to each controller in the zone. This allows the system software to address individual controllers if necessary.

## System Map

One of the key tasks for iC-Net integrators is to create a logical **System Map**, assigning device numbers to TV controllers so they fall into logical zones. The device mapping could be sorted by type or location; whichever suits the application.

iC-Net Zone	Zone	Room	Device	S1	S2
1	W 1 <sup>st</sup> Floor		<b>256</b>		
		W151	257	1	1
		W152	258	2	1
		W153	259	1+2	1
		W154	260	3	1
2	W 2 <sup>nd</sup> Floor		<b>512</b>		
		W251	513	1	2
		W252	514	2	2
		W253	515	1+2	2
		W254	516	3	2
3	E 1 <sup>st</sup> Floor		<b>768</b>		
		E151	769	1	1+2
		E152	770	2	1+2
		E153	771	1+2	1+2
		E154	772	3	1+2
4	E 2 <sup>nd</sup> Floor		<b>1024</b>		
		E251	1025	1	3
		E252	1024	2	3
		E253	1025	1+2	3
		E254	1026	3	3
5	Coffee Areas		<b>1280</b>		
		G100	1281	1	1+3
		G150	1282	2	1+3
		G151	1283	3	1+3
6	Day Care		<b>1536</b>		
		TV 1	1537	1	2+3
		TV 2	1538	2	2+3
7	Hallways		<b>1792</b>		
		W1	1793	1	3+3
		W2	1794	2	3+3
		E1	1795	1+2	3+3
		E2	1796	3	3+3
8	Office		<b>2048</b>		
		Admin	2049	1	4
		A/V Center	2050	2	4
All Zones	All		<b>4095</b>		

# Typical RF and ICC-Net Signal Flow

The diagram below shows the structure of a typical Contemporary Research media retrieval system. One of the key aspects for iCC-Net communication is to provide a forward and return (sub-channel) path for data if you're using ICC2 2-way TV Controllers.

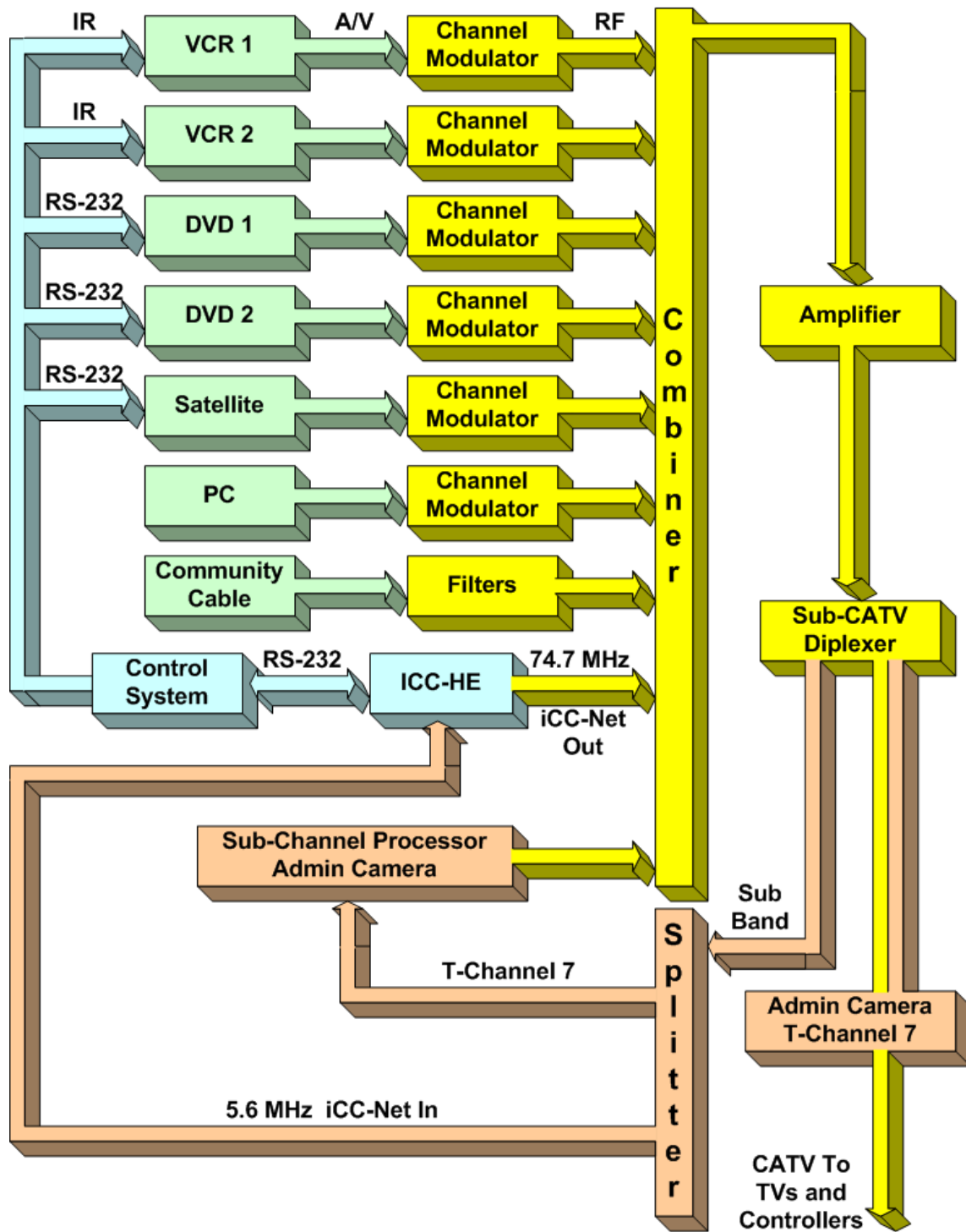

## Safety Instructions

### Read before operating equipment.

1. **Cleaning** - Unplug this product from the wall outlet before cleaning. Do not use liquid cleaners or aerosol cleaners. Use a damp cloth for cleaning.
2. **Power Sources** - Use supplied or equivalent UL/CSA approved low voltage DC plug-in transformer.
3. **Outdoor Antenna Grounding** - If you connect an outside antenna or cable system to the product, be sure the antenna or cable system is grounded so as to provide some protection against voltage surges and built-up static charges. Section 810 of the National Electrical Code, ANSI/NFPA No. 70, provides information with respect to proper grounding of the mast and supporting structure, grounding of the lead-in wire to an antenna discharge unit, size of grounding conductors, location of antenna discharge unit, connection to grounding electrodes, and requirements for the grounding electrode.
4. **Lightning** - Avoid installation or reconfiguration of wiring during lightning activity.
5. **Power Lines** - Do not locate an outside antenna system near overhead power lines or other electric light or power circuits or where it can fall into such power lines or circuits. When installing an outside antenna system, refrain from touching such power lines or circuits, as contact with them might be fatal.
6. **Overloading** - Do not overload wall outlets and extension cords as this can result in a risk of fire or electric shock.
7. **Object and Liquid Entry** - Never push objects of any kind into this product through openings as they may touch dangerous voltage points or short out parts, resulting in a fire or electric shock. Never spill liquid of any kind on the product.
8. **Servicing** - Do not attempt to service this product yourself as opening or removing covers may expose you to dangerous voltage or other hazards. Refer all servicing to qualified service personnel.
9. **Damage Requiring Service** - Unplug this product from the wall outlet and refer servicing to qualified service personnel under the following conditions:
  - When the power supply cord or plug is damaged.
  - If liquid spills or objects fall into the product.
  - If the product is exposed to rain or water.
  - If the product does not operate normally by following the operating instructions. Adjust only those controls that are covered by the operating instructions. An improper adjustment of other controls may result in damage and will often require extensive work by a qualified technician to restore the product to its normal operation.
  - If the video product is dropped or the cabinet is damaged.
  - When the video product exhibits a distinct change in performance, this indicates a need for service.

\* **Note to CATV system installer:** This reminder is provided to call CATV system installer's attention to Article 820-40 of the National Electrical Code (Section 54 of Canadian Electrical Code, Part I), that provides guidelines for proper grounding and, in particular, specifies that the cable ground shall be connected to the grounding system of the building as close to the point of cable entry as possible.

## **Limited Warranty and Disclaimer**

Contemporary Research Corporation (CR) warrants this product to be free from defects in material and workmanship under normal use for a period of two years from the date of purchase from CR. Should such a defect occur CR will repair or replace, at their option, the defective product at no cost for parts or labor.

This warranty extends to product purchased directly from CR or an Authorized CR Dealer. Consumers should inquire from selling dealer as to the nature and extent of the dealer's warranty, if any.

All warranty claims must be shipped pre-paid to the factory. Call or fax to obtain a Return Material Authorization (RMA) number.

CR is not liable for any damages caused by any of its products or for the failure of any products to perform, including any lost profits, lost savings, incidental damages, or consequential damages. CR is not responsible for any claim made by a third party or made for you by a third party. This limitation of liability applies whether damages are sought, or a claim is made, under this warranty or as a tort claim (including negligence and strict product liability), a contract claim, or any other claim. This limitation of liability cannot be waived or amended by any person. This limitation of liability will be effective even if CR or an authorized representative of CR has been advised of the possibility of any such damages.

Some states do not allow a limitation of how long an implied warranty lasts. Some states do not allow the limitation or exclusion of incidental or consequential damages for consumer products. In such states, the limitation or exclusion of the Limited Warranty may not apply to you. This Limited Warranty gives you specific legal rights. You may also have other rights that may vary from state to state. You are advised to consult applicable state laws for a full determination of your rights.

Except as expressly set forth in this Limited Warranty, CR makes no other warranties, expressed or implied, including any implied warranties of merchantability or fitness for a particular purpose. CR expressly disclaims all warranties not stated in this Limited Warranty. Any implied warranties that may be imposed by law are limited to the terms of this Limited Warranty.